

TOP VIEW

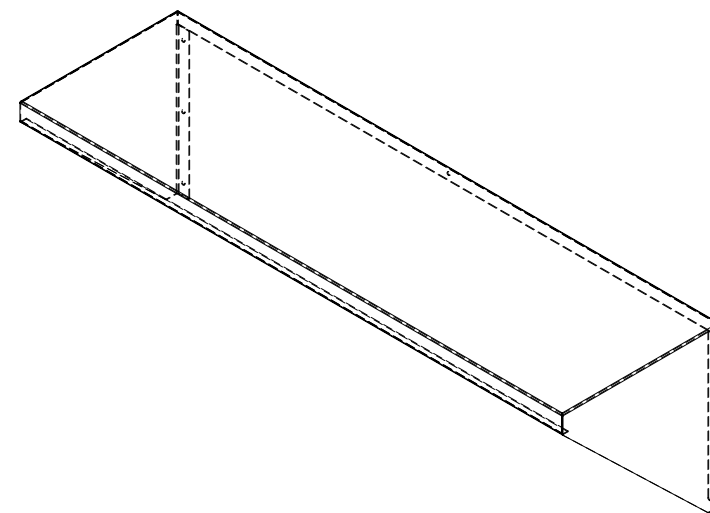

ISOMETRIC VIEW

NOTES:

1. MATERIAL: 16GA, 304 SS
2. FINISH: #4 BRUSHED
3. TOTAL WEIGHT: 19.24 LBS

PROPRIETARY AND CONFIDENTIAL:
 THE INFORMATION CONTAINED IN THIS DRAWING IS THE SOLE PROPERTY OF REGGIN INDUSTRIES INC. ANY REPRODUCTION IN PART OR AS A WHOLE WITHOUT THE WRITTEN PERMISSION OF REGGIN INDUSTRIES IS PROHIBITED.

UNITS:
 ALL DIMENSIONS ARE SHOWN IN INCHES [MILLIMETERS]

TOLERANCES:
 (UNLESS OTHERWISE NOTED)

INCHES	METRIC
X.X ± .03"	X ± .5
X° ± 1	X° ± 1
X/X ± 1/32"	

SHEET SIZE
 17" x 11"

DRAWN BY:
 B. KOSTKA
DATE:
 2021-06-23

CLIENT:
 SALES SHEET

PROJECT:
 PRODUCT STANDARD

SCOPE ITEM:
 WALL SHELF

DRAWING No.
 9003-1000-SS

SHEET TITLE:
 OVERVIEW

REVISION: 1	SHEET No. 1 of 1
-----------------------	----------------------------

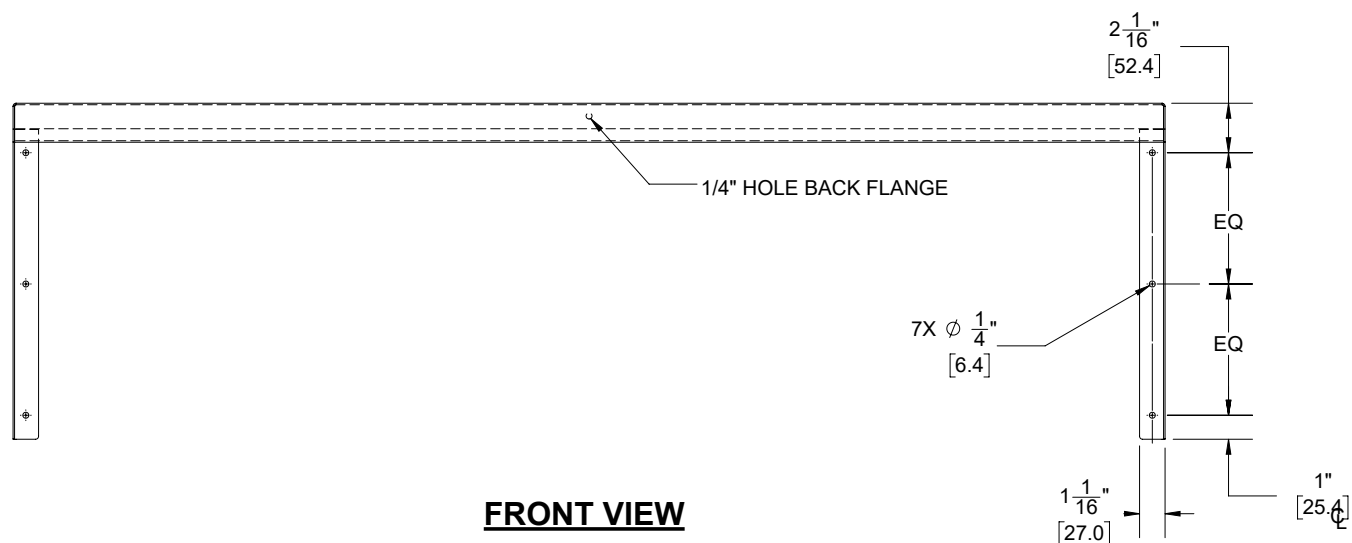

FRONT VIEW

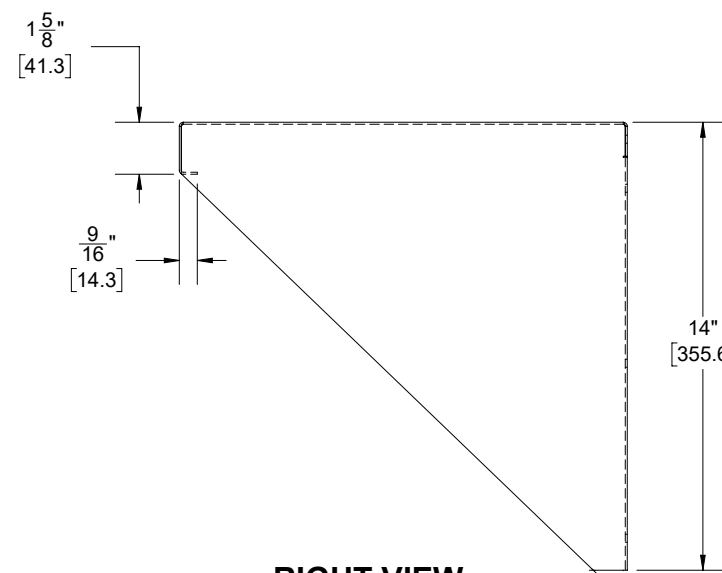

RIGHT VIEW

REVISIONS			
REV.	DESCRIPTION	DATE	REVISED BY:
1	RELEASED FOR SALES	2021-06-23	B. KOSTKA

1